



## UMA POWERTRONICS PVT. LTD.

"UMA HOUSE", Plot No.10, B/h. Near Metro Automobile, Near Railway Over Bridge,  
Jamnagar-Rajkot Highway, At. Hapa, Dist. Jamnagar - 361120. (Gujarat) (India)

CONTACT : 0288-2571524, 2571624 | Email : info@alfaups.in | Web : www.alfaups.in



INVERTER - UPS

**UNINTERRUPTIBLE  
POWER SUPPLY**

**USER'S MANUAL**

## 9 SPECIFICATIONS

- Full Digital Signal Processing using the latest DSP technology
- IGBT Rectifier so high input power factor
- Dynamic Bypass with Eco mode
- Wide Input Voltage Range
- Compatible with Engine Generators
- High Reliability for Maximum System Availability
- Handles 3:1 Crest Factor Loads
- Intelligent Battery Management
- Large LCD Display and Mimic Panel for Real-time information
- Output Isolation between UPS and Critical Load
- Low Electromagnetic Interference
- Complies with International Safety standards



3 phase in 3 phase out ( 6 to 150 KVA)

CAPACITY	KVA	10 KVA	15 KVA	20 KVA	30 KVA	40 KVA	50 KVA	60 KVA	80 KVA	100 KVA
	WATT	8 KW	12 KW	16 KW	24 KW	32 KW	40 KW	48 KW	64 KW	80KW
TYPE	Low Frequency Transformer Based True On Line-Double Conversion									
IN PUT	Phase	Three Phase + N ( Four wire )								
	Input Power Factor	≥ 0.85								
	Input Voltage Range	415 VAC ± 25 %								
	Input Frequency Range	50Hz ± 10 %								
	Output Ripple	< 5 %								
	Soft Start	0~100 % 5 sec								
OUT PUT	Nominal Voltage	400 VAC ± 1.5 ( 3 P + N )								
	Output Voltage Regulation	±1 % ( linear load), ± 3% ( Non Linear load)								
	Output Frequency Range	50Hz ± 0.5%								
	Crest Factor	> 3:1								
	Output Total Harmonic	Pure Sine Wave,								
	Distortion (THD)	Linear Load < 3%, Non-Linear Load<5%								
	Dynamic Characteristics	Instant voltage<±5% ( from 0 to100% ), Instant recover time<10ms								
	Overload Capacity	At 115% load, normal work, At 125% load 10 min, At 150% load 1min, At 200% load 1S								
	Inverter Efficiency	>92% ( full load )								
	BATTERY	Nominal DC Voltage	360	360	360	360	360	360	360	360
Float Charging Voltage		406	406	406	406	406	406	406	406	406
Equalized Charging Voltage		426	426	426	426	426	426	426	426	426
Charging Current		2-10 Amp Setable								
Low Voltage Alarm		315	315	315	315	315	315	315	315	315
Low Voltage Trip		300	300	300	300	300	300	300	300	300
High Voltage Trip		435	435	435	435	435	435	435	435	435
BY PASS	Phase	Three Phase ( 3 P+N )								
	Manual	Maintenance by pass switch provided								
	Static	No break								
PROTECTION	Input Protection	Input voltage, frequency under, over limit protection								
	Output Protection	Over current, short circuit, over voltage, low voltage								
	Battery Protection	Over charge, over-discharge protection								
	Temperature Protection	inverter over temperature protection								
GENERAL PARAMETERS	Working Environment	Temp: -10~40°C, relative humidity: 30%~90%								
	Communication Interface	RS232/ RS485, optional dry contact, SNMP card ( for remote control via internet )								
	Parallel Operation	Hot stand by								
	Protection Level	Ip21								
	Safety Performance	V in-n, V out-n 2000Vac, creepage<10mA, insulating resistance >2 MΩ (500VDC)								
	Noise (dB)	50-55								
	Dimension W X H X D (MM)	580 X 990 X 750	875 X 975 X 800	1160 X 980 X 770	1400 X 1150 X 810					
Weight (Kg)	185	210	230	295	310	350	490	750	850	

The great mass of computer system have equipped UPS to avoid system failure and datum damage due to utility power fault, you can monitor and control the power status through the connection between the communication interface and UPS.

You can get UPS status through the connection between computer and RS232 communication interface on back panel of UPS. User can connect UPS to the computer and know the running status of UPS at any moment through the computer interface, software and OS such as DOS, WINDOWS3.1, WINDOWS95, WINDOWS/NT, NOVELL, etc when utility power disconnected, system can know that utility fault and send out alarm information. When the reserved time goes, UPS will automatically save files and close system normal, and then automatically shutdown UPS power. When utility power come back, UPS will automatically run and system can automatically also come back to operate.

The computer interface of UPS offer detailed datum and is suit to net route, workstation, monitoring system, PC, etc Computer interface: It can sostenuto transmit datum through RS232 communication series port and computer. The datum that UPS offers includes input voltage value, output voltage value, output frequency, input frequency, battery capacity percent, used load percent, UPS internal temperature, etc.

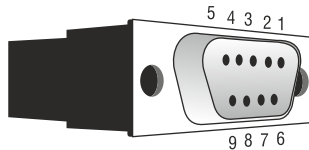

### CONTENTS

<b>1 BRIEF INTRODUCTION</b> .....	1
1.1 PROLEGOMENON .....	1
1.2 FIVE DESIGN POINTS .....	1
1.3 NOTE .....	1
<b>2 CONFIGURATION AND FUNCTION</b> .....	2
2.1 FRONT PANEL .....	2
2.2 APPERANCE .....	3
2.3 SWITCH POSITION AND FUNCTION .....	3
<b>3 PLACEMENT NOTES</b> .....	3
3.1 TRANSIT OR MOVE .....	4
3.2 PLACEMENT .....	4
<b>4 INSTALLATION</b> .....	5
4.1 TRANSIT OR MOVE .....	5
4.2 IN PUT, OUT PUT & DC INPUT WIRING .....	5
<b>5 OPERATION PROCESS</b> .....	6
5.1 PREPARE BEFORE START-UP.....	6
5.2 OPERATION PROCESS FOR FIRST START-UPS .....	7
5.3 OPERATION PROCESS FOR ROUTINE TURN- OFF.....	7
5.4 OPERATON PROCESS FOR LONG-TIME NO SWITCH ON/OFF .....	8
<b>6 MOVEMENT HANDLING</b> .....	8
6.1 UPS SYSTEM CONFIGURATION BLOCK FIGURE .....	8
6.2 UPS RUNNING WAY WHEN UPS RUNS NORMALLY .....	8
6.3 UPS RUNNING WAY WHEN UTILITY DISCONNECTED .....	9
6.4 UPS RUNNING WAY WHEN UPS RUNS ON BYPASS MODE .....	9
6.5 BATTERY AND CHARGE.....	10
6.6 DAILY MAINTENANCE .....	10
<b>7 COMMUNICATION INTERFACE</b> .....	11
<b>8 SPECIFICATIONS</b> .....	12

# 1 BRIEF INTRODUCTION

## 1.1 PROLEGOMENON

The product is designed specially aiming at the requirement of MINT and MICRO level computer with exquisite quality and excellent function easy to operate. With the development of customer office automatism and computerism, considering the bulk and the position of posing space, the noise disturbance to personnel in office, the light, thin, short and small product is our design direction, and we stress low noise. So this product is optimum supply power partner for office and makes you can attain optimal clean power quality.

## 1.2 FIVE DESIGN POINTS

1. Small bulk and no occupation space
2. Light weight and convenience to transit
3. Beauty and nature, easy to install
4. Convenient to maintain and easy to operate
5. Package material with environment protection and no pollution to environment

## 1.3 NOTE

The manual makes you can operate and maintain the system easily. To normally exert all functions of the system, please note the following :

1. Read the manual carefully before use
2. Perform the operation strictly according to operating process
3. Place the equipment carefully and lightly when moving the equipment
4. Install the power according to illumination in the manual
5. Please do not open the cover to avoid injury caused by electrical shock.
6. Please charge batteries once every a period if no used for long time
7. Do not use UPS on the condition of overload to avoid UPS Fault
8. Please carefully keep the manual for the future reference
9. Please handle the system according to "ABNORMITY HANDLING PROCESS" if there presents any abnormal phenomenon in machine
10. Please keep UPS neatness and cleanness

## 6.5 BATTERY AND CHARGE

1. When power switch on back panel is on the position of "ON", the batteries can automatically be charged and the charger can charge 90 % of the battery capacity after 10 hours
2. The time that battery supplies power has relation with using rate of load.

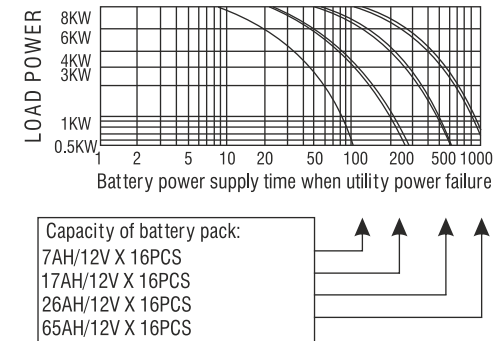

If you want to extend the time that the battery supplies power, please ask the professional to increase the battery number and don't make bold to install the battery to avoid any danger. Please keep the battery full voltage level to extend the battery life. There are many electron components and there also present high voltage in UPS, so non-technician can't open the panel of UPS to avoid any danger. With regard to installation and using, please refer to the prescript in this manual.

## 6.6 DAILY MAINTENANCE

UPS should be cleaned and maintained termly, avoid any dust to. Please clean UPS lightly with soft cloth, don't use grit for instead for. Termly inspect all kinds of connection every month and avoid any hit, ensure machine life ever. Looseness or humidity. Please keep good ventilation at inlet/outlet hole, termly inspect the hole every month and confirm if there is any jam at inlet/outlet hole. The battery is dry-type and maintenance-free and needless to maintain. If the battery you use is LEAD-ACID battery used by auto, you must inspect the electrolyte in the battery once every month, if the electrolyte is too low, please add distilled water into the electrolyte.

### 6.3 UPS RUNNING WAY WHEN UTILITY DISCONNECTED

when utility disconnected, power is battery supplied to the inverter then is sustention transmitted to user equipment for using via the static switch and the filter to avoid power disturbance to load

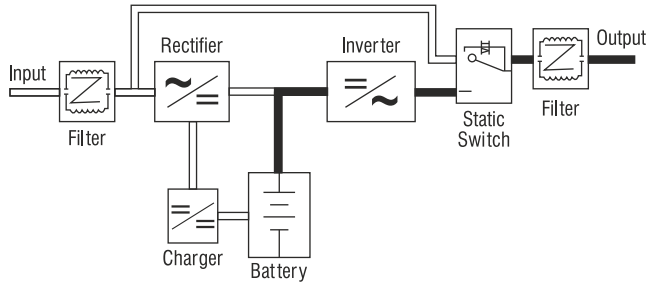

### 6.4 UPS RUNNING WAY WHEN UPS RUNS ON BYPASS MODE

There are five kinds of status when UPS runs on bypass mode

- 1 overload
- 2 inverter failure

when startup, UPS is in the course of slow startup during 20 seconds by pressing the "SWITCH ON" button.

When switch off, please press the "SWITCH OFF" button.

5. UPS runs under the condition of internal over-temperature -17

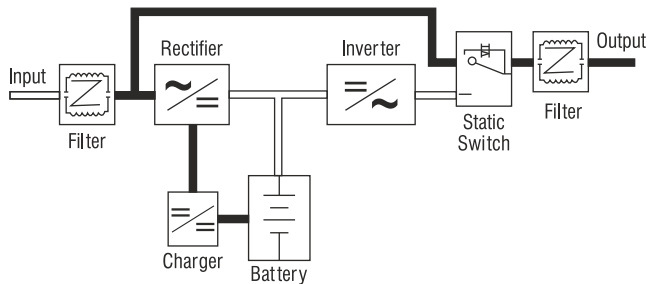

## 2 CONFIGURATION AND FUNCTION

### 2.1 FRONT PANEL

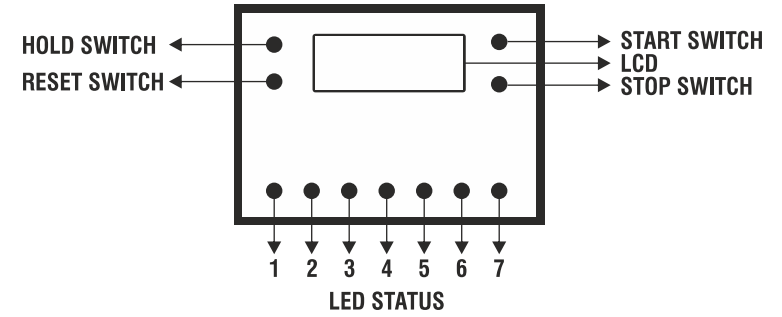

- 1 - UPS ON MAINS
- 2 - UPS ON BATT
- 3 - O/P HIGH
- 4 - O/P LOW
- 5 - BATT. HIGH
- 6 - BATT. LOW
- 7 - OVER LOAD

HAVE A NICE DAY
NX - ONLINE UPS
SYSTEM CAPACITY
KVA      PCV

I/P VOLTAGE
RN : —
YN : —
BN : —

O/P VOLTAGE
RN : —
YN : —
BN : —

O/P CURRENT
R : —
Y : —
B : —

UPS ON / OFF
PC VOLT

## 2.2 APPEARANCE

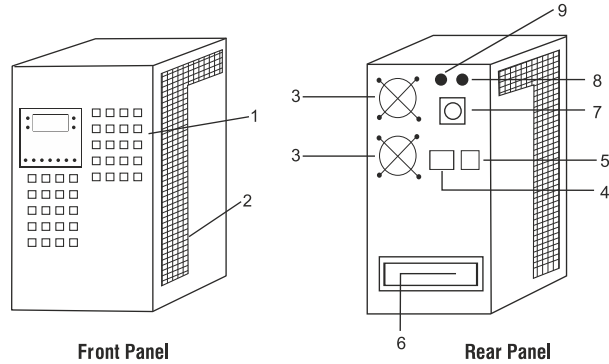

1. Control panel : UPS display and operation panel.
2. Emission heat ventilation hole : For air circulation
3. Cooling Fan
4. MCB switch : For Input AC power
5. MCB switch : For Batt. + ve
6. Wiring terminal strip : Power wiring for Input and Output
7. Manual Bypass switch : For bypassing the UPS
8. PH. SQ.
9. Temp High

## 2.3 SWITCH POSITION AND FUNCTION

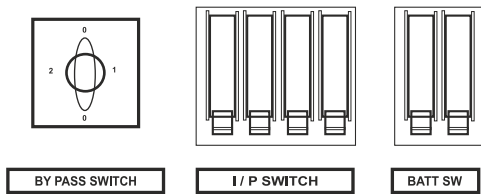

- Input switch : when turn on the switch, the UPS is connected with AC power.
- Battery switch : When turn on the switch the UPS is connected with battery power.
- Bypass switch : When put rotary switch in to position 2 UPS is bypass and load connected directly to grid supply.

## 5.4 OPERATION PROCESS FOR LONG-TIME NO SWITCH ON/OFF

- If UPS is not used above ten days, please first turn off UPS by pressing the "OFF" button on front panel, then switch the Input and MCB switch on back panel to the position "OFF".
- If UPS is not used above three months, please run UPS for above 24 hours reference to the first start-up process and keep the battery at the full voltage level to extend battery life.

## 6 MOVEMENT HANDLING

### 6.1 UPS SYSTEM CONFIGURATION BLOCK

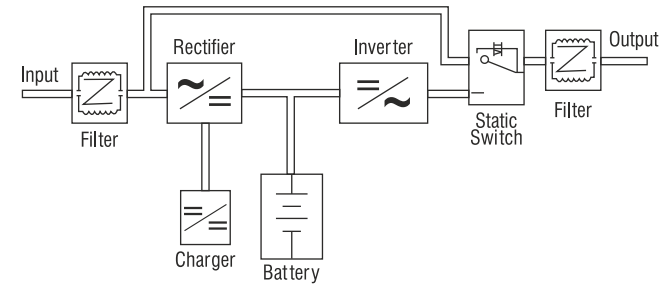

### 6.2 UPS RUNNING WAY WHEN UPS RUNS NORMALLY

When UPS runs normally, after high-frequency harmonic noise in utility power is filtered by the filter, on one hand utility power charges battery pack via the inverter and keeps battery power on full voltage level, on the other hand utility power is converted into DC power via the rectifier and is converted into pure sine wave power via the inverter, finally power is transmitted to user equipment for using via the static switch and the filter.

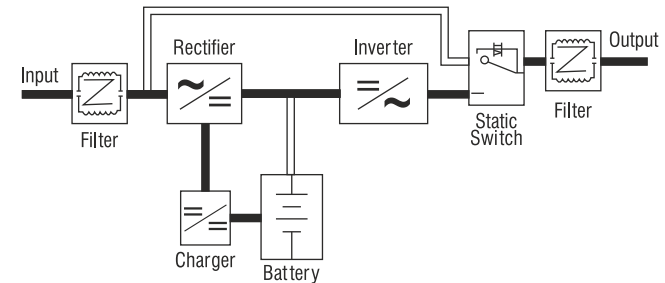

## 5.2 OPERATION PROCESS FOR FIRST START-UP

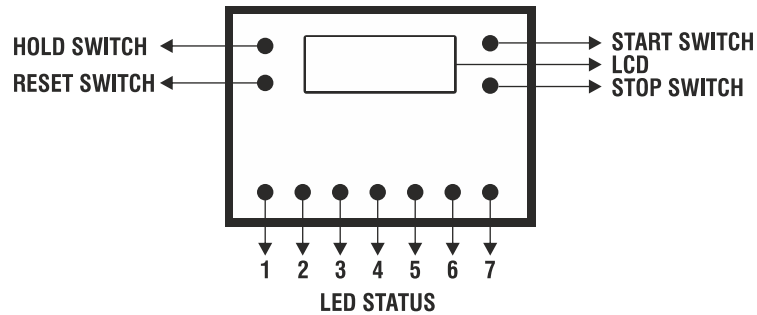

- Operation process for first start-up After verify the above items are correct, please turn on UPS according to the following ways
- Please switch (Input MCB) on the back panel to the "ON" position. The Online indicator is solid and LCD display is lit on.
- Please switch (Batt MCB) switch on the back panel to the "ON" position.
- Press the ON" button on front panel for 5 sec. As above figure. The On Line indicator and the Output on indicator are solid and LCD display is lit on. Output power is on.
- Shutdown input power of UPS, Online indicator light is off the welcome information is displayed on LCD, and output is UPS inverter powered. UPS sounds for few seconds, which indicates UPS runs on battery mode at present. The sound will automatically stop 10 s later. UPS will sound alarm every 1 s again when battery power is to be exhausted. The Fault indicator is solid and LCD show Batt low.
- Online indicator will be lit on when utility power source is resumed. Press up down switch to switch items displayed. Inspect display parameters are normal, thus first start up procedure has been completed. Please measure output volatage and see if it meets the requirement, then connect the load to UPS output terminal. Use pure power provided by UPS.
- After connect load press up down switch to switch items displayed till display the output power display percent % . If the value displayed is more than 100 % , please (Please dismantle the unimportant load till the value displayed is less than 100 %).

## 5.3 OPERATION PROCESS FOR ROUTINE TURN-OFF

- if you want to switch on /off UPS when daily using please operate UPS according to the following way.
- You can switch off UPS by pressing the "OFF" button on front panel. At the time UPS out put is off and the batteries are getting charged.
- Always turn on UPS by pressing down the ON button when daily operation.

## 3 PLACEMENT NOTES

### 3.1 TRANSIT OR MOVE

- Please dismantle all barge connection firstly. (First turn off before performing)
- Place lightly and carefully, forbid to hit.
- Please do not move UPS inverted.

### 3.2 PLACEMENT

- Do not place the UPS on the slope or scrag land.

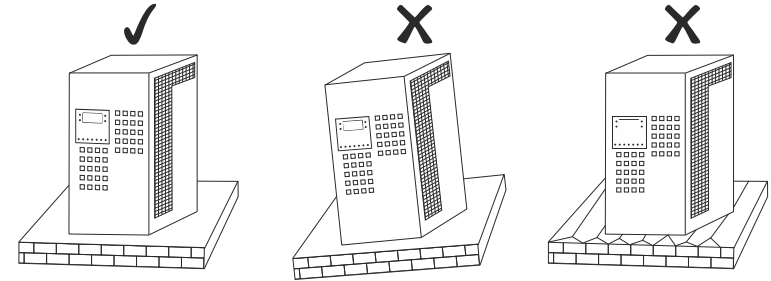

- Please place the UPS in the place where keeps good ventilation , rear panel of UPS and two side Faces should keep more than 10cm away from he wall
- Do not install UPS under sunlight , drain and damp place.

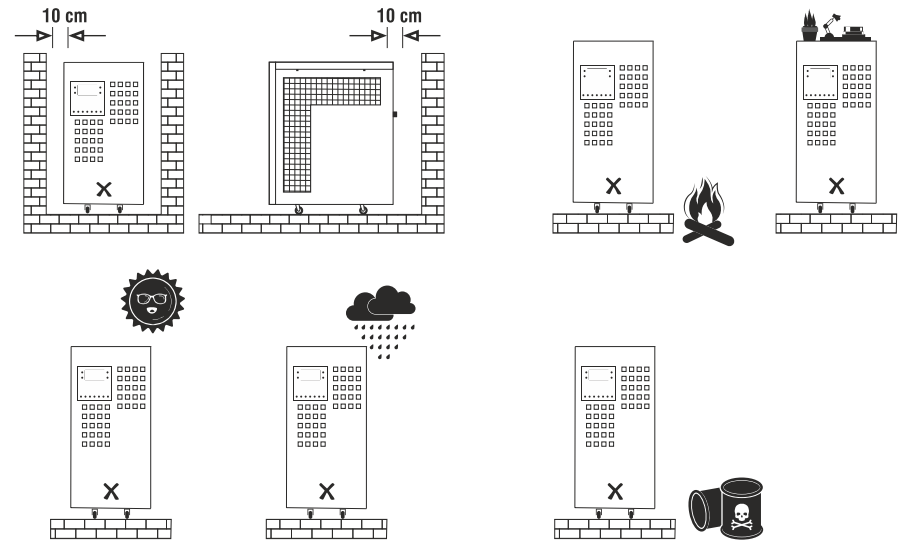

- Please keep away from fire source and high temperature to avoid over-high temperature.
- Do not lay goods on the UPS.
- Do not install UPS in the place where contains caustic gas.
- Running environment temperature: 0°C-40 C.

## 4 INSTALLATION

### 4.1 INPUT, OUTPUT AND BATTERY

Prohibit using general household socket, because the Max current of general socket is 15A, the socket may be burned down because of overload.

Please connect UPS input terminal to utility power in nearby switchboard.

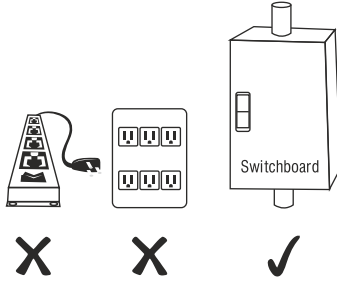

- Position and way of connect
  - (1) Remove two screws with "+" screw-driver.
  - (2) Open the back panel and inspect the wiring terminal below the power switch.
- Relock the special cover after completing connection.
- Please first fetch in the power cables of input, output and batteries pack through inlet/outlet hole of distribution electricity and then barge connect to terminal plate.

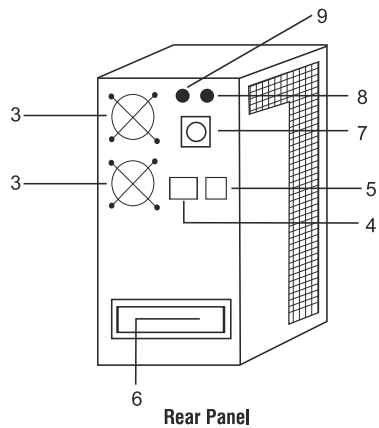

Rear Panel

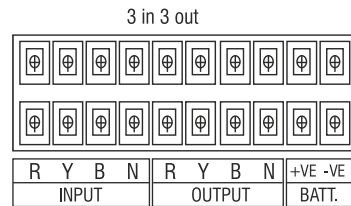

## 5 OPERATION PROCESS

### 5.1 PREPARE BEFORE START-UP

- Prepare before start-up. To make UPS normally and correctly run, please confirm the following items.
- Verify power switch on back panel is on the "OFF" position..
- Verify the installation position again (Figure 4 to 10)
- Rock power cable by hand and see if there is any looseness, retighten them if looseness.
- Do not connect load.
- Inspect if input voltage meet the demand of UPS ( 415V + 10 % ) with ammeter.